

## Design of a GSM Based Electronic Voting Machine with Voter Tracking

Vaibhav Bhatia<sup>1</sup> and Rahul Gupta<sup>2</sup>

Submitted in April, 2014; Accepted in December, 2015

**Abstract** – This paper presents the design of a GSM based electronic voting machine with voter tracking. The design presented here follows a GSM based approach to send the polling results to a base station via mobile network. Infrared sensors have been used for tracking the information regarding the voters. After the voting process has been over, the results are sent to the base station for various analyses and declaring the verdict. This system is more secured and chances of tampering the results are reduced. The simulation of the system is done on Proteus Professional Software v8.0. The design presented in this paper is more secured and appropriate according to modern day requirements.

**Index Terms** – Infrared Sensor, GSM, Microcontroller, Security, Voting.

### 1.0 INTRODUCTION

Voting is the most pivotal process which is carried out to reveal the opinion of the people in selecting government or in any issue that is under consideration. So the conventional voting systems based on paper voting are being replaced by electronic voting machines. Voting is a decision making mechanism in a society and security is indeed an essential part of voting. The term “electronic voting” represents the practice of electronic means in voting to safeguard the security, reliability, and transparency. The crucial role in determining the result of an election, electronic voting systems should be developed with the greatest responsibility and security. Electronic voting machines aid blind users by reading off the instructions using headphones and also provide essential tools to help people with disabilities. Voting machines are the combination of mechanical and electronic equipments which are needed for casting votes and displaying the election results. The main proposal for using the voting machines was given in 1838 [1]. There are large number of smart systems present which employ microcontrollers for their operation [2-4] and several other voting systems have been developed for ensuring a secured vote casting process [5-7]. The design presented in [8] incorporates voter information facility for getting the information about the number of voters at a place. In this paper, GSM based design of an electronic voting machine has been presented for sending the polling results to a monitoring station via mobile network. This system is fully secured and chances of digital tampering are also avoided [9-10].

<sup>1</sup>Department of Electrical and Electronics Engineering, Bhagwan Parshuram Institute of Technology, New Delhi, India

<sup>2</sup>Department of Electronics and Communication Engineering, Maharaja Agrasen Institute of Technology, New Delhi, India  
E-mail: <sup>1</sup>vaibhav.bhatia25@gmail.com

Number of voters at the polling place can be tracked by using infrared sensors. The functions performed by the proposed voting machine includes:

- a. To cast votes to the candidates
- b. Voter Tracking
- c. Vote Rejection option available
- d. Results are sent to monitoring station via GSM

This paper is organized as: Section 2 describes the GSM modem, Section 3 shows the block diagram of the system, Section 4 describes the power supply schematic, Section 5 shows the development tools used, Section 6 shows the circuit simulation, Section 7 describes the results and conclusions and Section 8 discusses the future scope.

### 2.0 GSM MODEM

A GSM modem is a specialized kind of modulator-demodulator in which a SIM card is accepted and it can be operated over a subscription to the mobile operator. GSM module is used when a communication between a computer and a GSM system is required. In many countries it is used as architecture for mobile communication. GSM module consists of a GSM modem and communication interfaces like RS-232, USB along with a power supply circuit for computer. GSM modem communicates over the mobile network when connected to a computer [11-12]. GSM modems are also used to send and receive SMS and MMS messages. A GSM can be easily interfaced with the microcontroller system and uses serial communication for data transfer. Fig. 1 shows a GSM module:

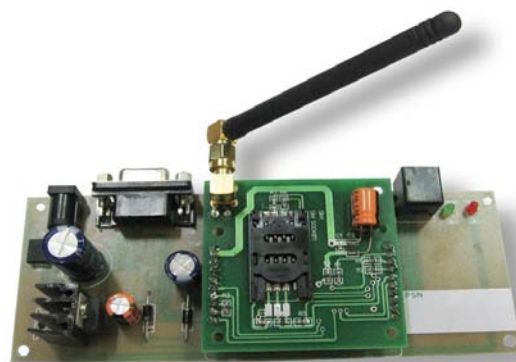

**Figure 1: GSM Module**

GSM Module is used to accomplish the following functions:

- a. To receive and send messages.
- b. To make, receive and reject a voice call.

**3.0 BLOCK DIAGRAM OF THE SYSTEM**

For the development of the system, PIC16F877A microcontroller based on the modified Harvard architecture developed by microchip technology has been used. Fig.2 shows the block diagram of the system. Various sensors and devices interfaced with the microcontroller are shown. The machine design consists of:

The machine design consists of:

**3.1. Crystal Oscillator**

It is an oscillator circuit that deploys the property of mechanical resonance of the piezoelectric crystals for creating an accurate electrical signal. The frequency of the crystal by keeping a track of time, provides clock signal to the microcontroller. Quartz crystal of frequency 4 MHz is used in the proposed system. Quartz crystals are used in wrist watches, calculators, counters, signal generators, and oscilloscopes.

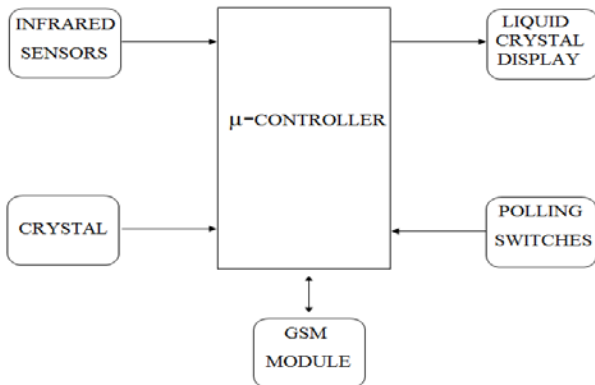

**Figure 2: Block Diagram of the System**

**3.2. Infrared Sensors**

Infrared (IR) sensor is an electronic device consisting of transmitter and receiver LED. The transmitter LED continuously emits IR rays and when an object is close to the sensor, the rays bounce off the object and received into the receiver LED. Infrared sensors are generally used in IR imaging devices, gas analyzers, and radiation thermometers. IR sensors are used in this system to track the voter count which is used at later stage for analysis of polling results.

**3.3. Liquid Crystal Display**

A Liquid Crystal Display is dot matrix display that displays alphanumeric characters and symbols. Liquid crystal displays are used in battery-powered devices, such as digital watches, calculators, digital thermometers etc. 16X2 LCD has been used in the modeled system to display the candidate information and polling results.

**3.4. Polling Switches**

Polling Switches are used in the system to cast votes to the candidates. By pressing the switch, vote can be given to the desired candidate. Six switches have been used in modeled system to cast votes and one switch is for vote rejection. The polling results are displayed by pressing the last switch after

entering the correct password, thus making the system more secured and less prone to mistakes.

**3.5. GSM Module**

GSM Module is used in the system to send the polling results to the monitoring station via mobile network. In this way a more secured system is presented and the chances of anomalies are reduced.

**4.0 POWER SUPPLY**

Five volts power supply w.r.t ground is required for the operation of the microcontroller. Fig. 3 shows the circuit for the power supply used in the system.

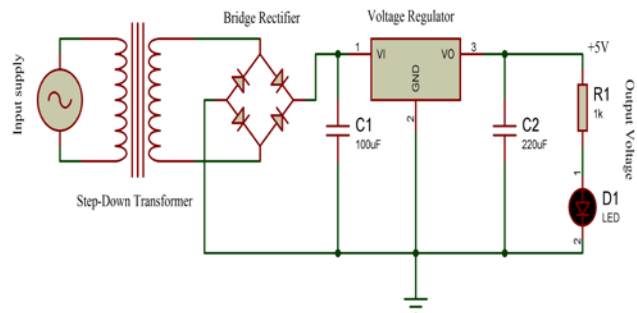

**Figure 3: Power Supply**

The step down transformer steps down the ac supply from the mains and bridge rectifier converts it into dc. This dc is passed through filter circuit to get a more smoothed waveform. Voltage regulator produces a fixed output voltage that remains constant irrespective of changes in its input voltage and load conditions. 7805 voltage regulator is used here, which gives +5 V output which is then given to microcontroller for its operation.

**5.0 DEVELOPMENT TOOLS**

The software of the machine is written in Embedded C language and the simulation of the system is done on Proteus Professional Software v8.0. MPLAB Integrated Development Environment has been used for programming the microcontroller.

**6.0 CIRCUIT SIMULATION**

A GSM based design of an electronic voting machine with voter tracking is presented in this paper, Fig. 4 shows the simulation schematic of the machine design and snapshot of voter count is also included (see Fig. 5). To enable the polling results to be displayed, an LCD having two by sixteen display is used. The LCD is connected to the PORT B of the microcontroller which is declared as the output port. The operation of the LCD is shown in Fig. 6.

Polling switches are used to give votes to the candidates. The design is proposed for four candidates representing different

parties, a switch is used to show the polling results after entering the correct password. There is rejection button available in the machine, which is pressed if voter does not want to choose a candidate. Infrared sensors are used for tracking the number of voters at the polling booth. After the voting process has been over, the results are sent to the monitoring station via GSM using mobile network. There is an added advantage of using GSM that the results data cannot be tampered as it is directly sent to the base station for analysis and results declaration. All the data consisting of number of voters present at the polling booth, number of votes rejected and number of votes given to the candidates is also sent to monitoring station for verification. This system is appropriate and the chances of mistakes are reduced. The final results are also displayed on the LCD after entering the correct password, thus making the system highly secured.

**7.0 RESULTS AND CONCLUSIONS**

A GSM based voting machine design with voter tracking has been proposed in this system which is found to be appropriate. The software of the system has been written in Embedded C language and Proteus Professional Software has been used for simulating the behavior of the machine. The simulation of the machine is working properly under normal conditions. Polling switches are used to give votes to the candidates and infrared sensors have been used to track the voter entries. The count of the voter entries previously stored in the register is matched with the total votes casted and votes rejected to avoid any mistakes thus making the system more protected. After the voting process has been over, the results are displayed on the machine LCD by entering the correct password and sent to the monitoring station via GSM for analysis and the declaration of the final verdict. Table 1 shows the comparative study of different voting systems. The design presented here is cost effective, highly secured and appropriate according to the modern day requirements.

**8.0 FUTURE SCOPE**

The design of the GSM based electronic voting machine with voter tracking proposed in this paper is accurate and it can be further improved in terms of power consumption using advanced VLSI applications.

**9.0 REFERENCES**

[1]. Douglas W. Jones, "Early Requirements for Mechanical Voting Systems", International Workshop on Requirements Engineering for E-voting Systems, Aug. 31, 2009.  
 [2]. Vaibhav Bhatia, Pawan Whig, "Performance Analysis of Multi Functional Bot System Design using Microcontroller", International Journal of Intelligent Systems and Applications, Vol. 6, no. 2, pp. 69-75, January 2014.

[3]. A. Drumea, P. Svasta, "Universal electronic module for industrial control based on system on chip device," 30th International Spring Seminar on Electronics Technology, ISSE 2007, Cluj-Napoca, Romania, pp. 232-235, May 2007.  
 [4]. Vaibhav Bhatia, Gavish Bhatia, "Room Temperature Based Fan Speed Control System using Pulse Width Modulation Technology", International Journal of Computer Applications, Vol. 81, no. 5, pp.35-40, November 2013  
 [5]. A. Villafiorita, K. Weldemariam, and R. Tiella, "Development, Formal Verification, and Evaluation of an E-Voting System with VVPAT," IEEE Transactions on Information Forensics and Security, vol. 4, no. 4, 2009.  
 [6]. S.Lavanya."Trusted secure electronic voting machine" International Conference on Nanoscience, Engineering and Technology (ICONSET), pp.505 – 507, 2011  
 [7]. D. Chaum , P. Y. Ryan and S. Schneider S. De Capitani di Vimercati , P. Syverson and D. Gollmann "A practical voter-verifiable election scheme", Proc. Comput. Security (ESORICS 2005), vol. 3679, pp. 118 -139, 2005.  
 [8]. Vaibhav Bhatia, Rahul Gupta, "A Novel Electronic Voting Machine Design with Voter Information Facility using Microcontroller" International Conference on Computing for Sustainable Global Development , pp: 311-313, March 5<sup>th</sup>- 7<sup>th</sup> , 2014.  
 [9]. A. Hasti, "Study of Impact of Mobile Ad – Hoc Networking and its Future Applications", BIJIT – 2012, January - June, 2012, Vol. 4 No. 1, ISSN 0973 – 5658.  
 [10]. Kusam, P. Abrol and Devanand, "Digital Tampering Detection Techniques: A Review", BIJIT-2009, July – December, 2009, Vol. 1 No. 2, ISSN 0973 – 5658.  
 [11]. V. Otsason, A. Varshavsky, A. LaMarca, E. de Lara, "Accurate GSM indoor localization," in Proceedings of the 7th International Conference on Ubiquitous Computing, pp.141-158, Tokyo, Japan, September 2005.  
 [12]. J. Cai, D.J. Goodman, "General Packet Radio Service in GSM", IEEE Communication magazine, October 1997.

**Table 1: Comparative study with existing voting systems**

Parameters	Other Systems	Our System
Control Unit	Microcontroller	Microcontroller
Security	Less secured	More Secured
Accuracy	Comparatively less accurate	More accurate
Cost	High Cost	Low Cost

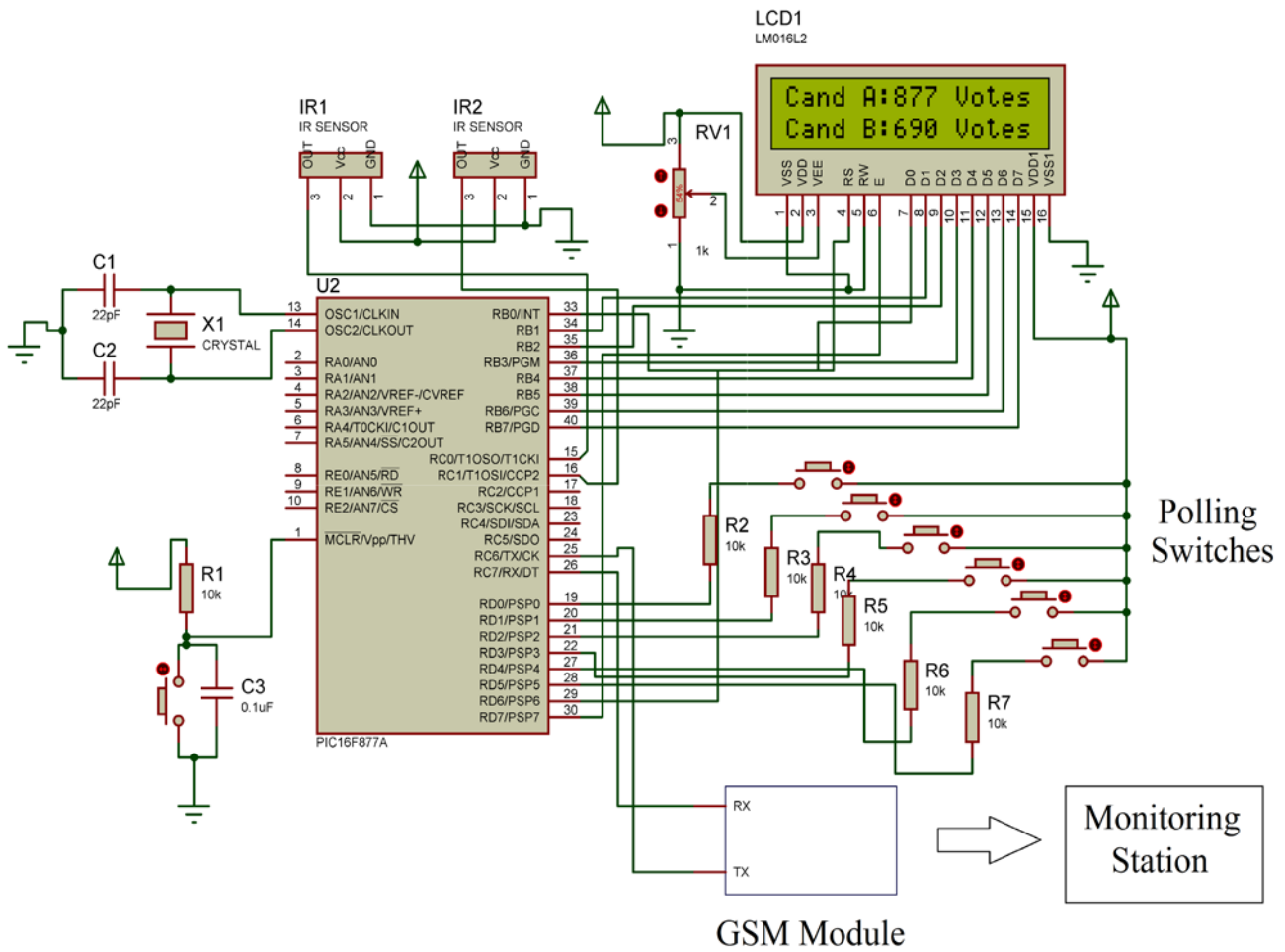

Figure 4: Simulation of the Machine

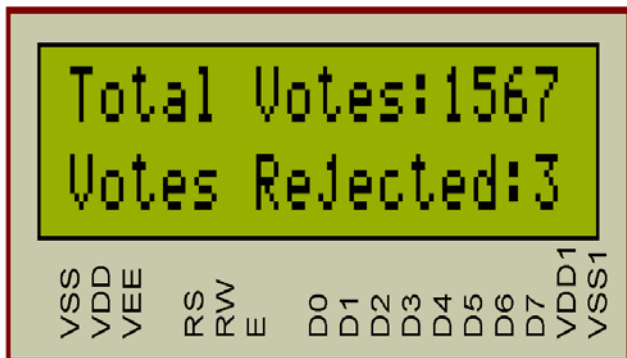

Figure 5: Snapshot of Counted Votes

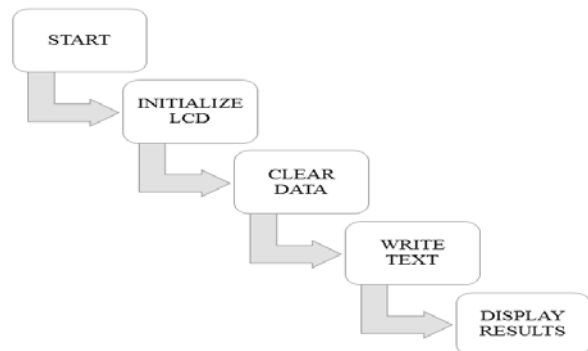

Figure 6: LCD Operation